

AISLE  
CONTAINMENT

SERVER  
RACKS



NETWORK  
RACKS

CABLE  
MANAGEMENT



# RACKS AND AISLE CONTAINMENT

SAVE TIME. SAVE MONEY. REDUCE RISK.

PRODUCT BROCHURE

[www.arctiv-tech.com/racks](http://www.arctiv-tech.com/racks)

# ArcTiv Racks and Aisle Containment

## PRODUCT LINE FEATURES



### Server Racks

Quality built IT racks with high-load rating, high ventilation doors and up to 52U options



### Network Racks

High-capacity IT racks with high-density cable management for networking applications.



### Aisle Containment

Automated doors and top panels for integration with building fire suppression systems.



### Beautiful Appearance

Curved rack doors, high quality steel, customized color options (Black, White) and tempered glass containment doors.



### Durability

Sturdy, high quality design and components from 100% SPCC steel frame and mounting rails.



### Easy Installation

Racks can ship either fully configured with pre-installed accessories or flat-pack with simple field installation.



### Modular Design

Simple to configure containment components and add on for future expansion.



### High-Density

Supports latest servers and network equipment with in-rack vertical cable management and top-rack accessories.



### High-Capacity

Supports advanced applications with up to 52U racks, high load rating (1500kg) and +78% airflow doors.



### Automatic Operation

Automatic containment doors and top panels can sync with building fire detection and suppression systems.



### Security

Locking containment and rack front & rear doors which can integrate with iPDU e-handle systems.



# ArcTiv Racks and Aisle Containment

## PRODUCT LINE BENEFITS

### Save Time. Save Money. Reduce Risk.

ArcTiv Racks & Aisle Containment include easy-to-manage solutions to support critical IT systems.

#### Save Time.

Reduce installation time with pre-assembled racks and accessories. Fast assembly flat pack and modular systems reduce shipping costs and installation time.

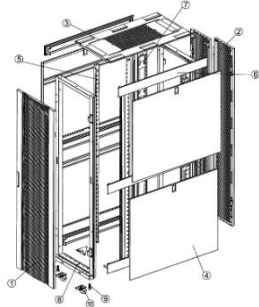

#### Fast Assembly

Easy to build, semi-welded frame for flat pack freight.



#### Pre-Assembled

Pre-configured racks & accessory options.



#### Modular Design

Easy to design, install and scale for future expansion.

#### Save Money.

Lower your total CAPEX & OPEX with reduced data center whitespace, high cooling efficiency, and customize around existing facility floorspace.

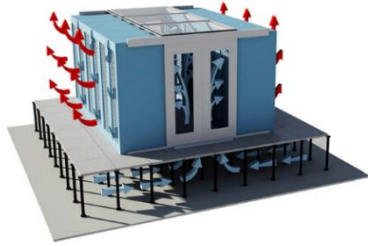

#### Lower Cooling Costs

Hot & cold air isolation increases efficiency.



#### Minimize Floorspace

Taller racks reduce total whitespace requirements.



#### Customizable

Customizable for buildings conversions or expansions.

#### Reduce Risk.

Manage and secure high-performance servers and IT equipment in high-density racks with high load ratings, automatic doors and top panels.



#### High Rack Density

Supports iPDU's & vertical cable management



#### High Load Rating

High quality, SPCC steel with adjustable rails.



#### Automatic Operation

Top panels sync with fire suppression systems.



# ArcTiv Server Racks

## PRODUCT FEATURES



Front View



Rear View

ArcTiv Server Racks include a beautifully designed, semi-welded frame ideal for storing servers and IT equipment in Data Centers and Server Rooms.



### Beautiful Appearance

Curved rack doors, high quality steel, customized color options (Black, White).



### Easy Installation

Fully configured racks or flat-pack with simple field installation.



### High-Capacity

Up to 52U racks, high load rating (1500kg) and +78% airflow doors.



### Security

Locking rack front & rear doors with multi-bay compartment options

## Product Highlights



Curved Door with 130° Radius



HD Castors & Leveling Feet



Multi-Bay Compartments



Split Locking Side Panels



High Airflow, Vented Locking Doors



Adjustable Mounting Rails



# ArcTiv Network Racks

## PRODUCT FEATURES

ArcTiv Network Racks offer high-density solutions for storing networking and storage equipment in Data Centers and Server Rooms.



### Beautiful Appearance

Curved rack doors, high quality steel, customized color options (Black, White).



### High-Density

Supports in-rack vertical cable management and high density iPDU's



### High-Capacity

Up to 52U racks, high load rating (1500kg) and +78% airflow doors.



### Security

Locking rack front & rear doors which can integrate with iPDU e-handle systems.



CE

Front View

Open View

## Product Highlights



Vertical Cable Management

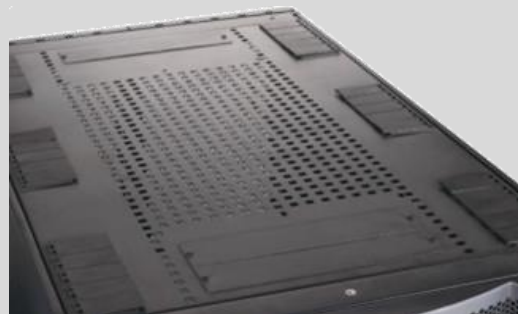

Top Cable Entry Access Holes



Tool-less iPDU Mounting



Network & Power Cable Separation

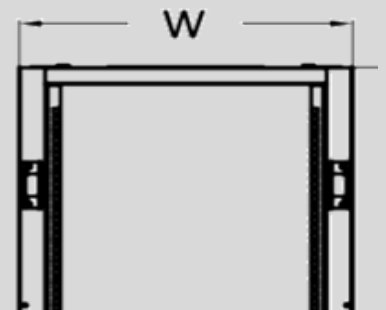

750 & 800mmW Options



# ArcTiv Server & Network Racks

## ORDERING INFORMATION & ASSEMBLY

### Rack Assembly & Packaging:

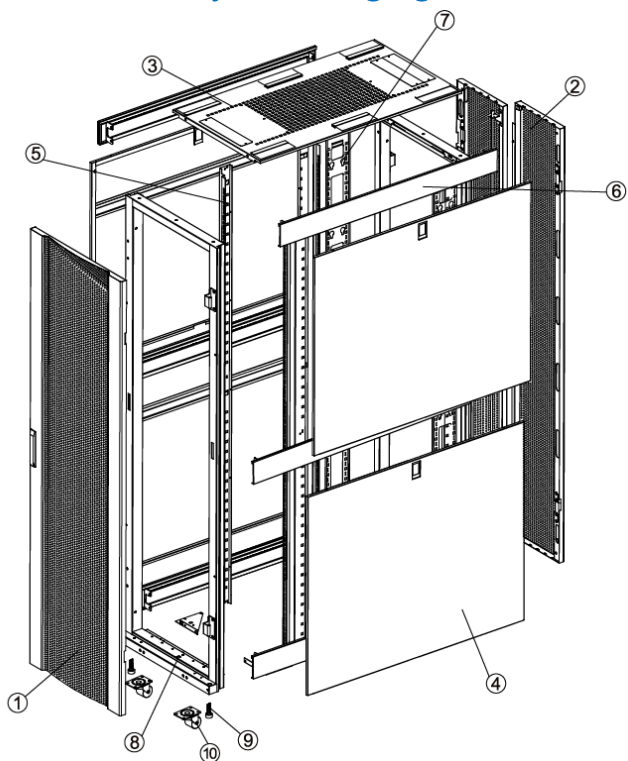

Item	Component	Quantity
1	Front vented door with lock	1
2	Rear door	2
3	Top cover	1
4	Side panel	4
5	Vertical rail	4
6	Horizontal beam	6
7	Cable management rail	2
8	Door frame	2
9	Leveling feet	4
10	2" heavy duty castor	4

### Flat Pack Cartons

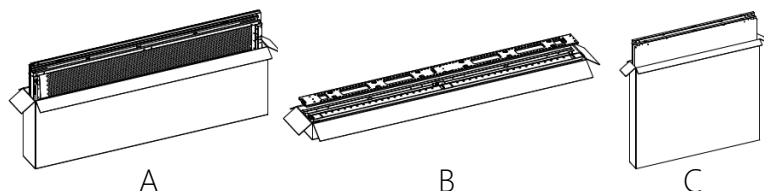

### ArcTiv Racks Include:

- Semi-Welded Frame with 1500kg Load Rating
- Vented Front Door, 78%, with 130° Radius
- Split, Rear Vented Doors, 78%
- 2 x Locking Swing Handles (front & rear)
- Vented Top Panel with Cable Entry Access
- 4 x Locking and Removable Split Side Panels
- 4 x EIA Adjustable Mounting Rails
- 2 x Rear Mounting Cable / PDU Channels
- 4 x Heavy Duty Castors and Leveling Feet
- Baying & Grounding Kit
- Pack of 50 M6 Screws and Cage Nuts
- Black Powder Coat Paint (RAL9005)
- Pallet (Assembled)
- CE certified, IP20 Compliant
- 2-Year Warranty

### Part Numbers (Standard Models):

AT [R]	[W]	[D]	[H]
Rack Type	Width	Depth	Height
[SVR] = Server Rack	6 = 600	08 = 800 10 = 1070	42 = 42U 45 = 45U
[NWR] = Network Rack	8 = 800	12 = 1200	48 = 48U

Examples:

**ATSVR61042** = Server Rack, 42U x 600mmW x 1070mmD

**ATNWR81242** = Network Rack, 42U x 800mmW x 1200mmD

### Customized Options

- Rack Sizes
- Door & Handle Types
- Colors (White, RAL7035)
- Packaging (Flat-Pack)
- Multi-Bay Compartments
- Cable Entry Access

# ArcTiv Rack Accessories

## ORDERING INFORMATION

### Popular Rack Accessories (Ordered Separately)

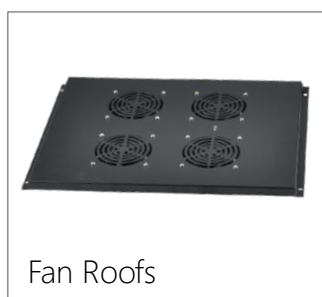
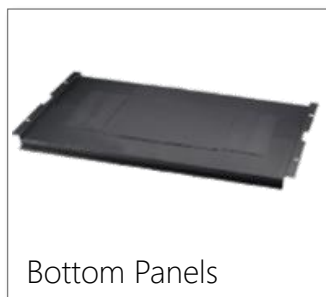
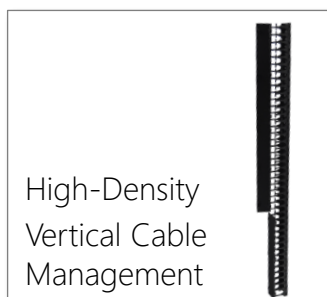

### Rack Accessories

	Part No	Description	SERVER RACK	NETWORK RACK
CABLE MGMT	ATHDHCM2U	High-Density Horizontal Cable Manager, 2U	●	●
	ATHCM1U	Plastic Horizontal Cable Manager, 1U	●	●
	ATPDRING1U	Horizontal D-Ring Manager, 1U	●	●
	ATHDVCM42	High Density Vertical Cable Manager, 42U		●
	ATVCM1U	Plastic Vertical Cable Manager, 42U, 1U	●	●
	ATPCT6	Power Shielding Cable Trough, 600mmW	●	
	ATPCT8	Power Shielding Cable Trough, 800mmW		●
	ATDCT6	Data Shielding Cable Trough, 600mmW	●	
	ATDCT8	Data Shielding Cable Trough, 800mmW		●
	ATVELCRO	Velcro Straps	●	●
AIRFLOW & OTHER	ATFROOF61	Fan Roof (6, 600mmW, 1000mmD)	●	
	ATRFROOF81	Fan Roof (6, 800mmW, 1000mmD)		●
	ATBPANEL61	Bottom Panel (600mmW, 1000mmD)	●	
	ATBPANEL81	Bottom Panel (800mmW, 1000mmD)		●
	ATP2UPANEL	Plastic Tool-less Blanking Panel (2U)	●	●
	ATFSHELF-5	Fixed Shelf, 550mmD	●	●
	ATSSHELF-5	Sliding Shelf, 550mmD	●	●





# ArcTiv Aisle Containment

## PRODUCT FEATURES



*Modular Cold-Aisle Containment System*

**ArcTiv Aisle Containment** are modular, row-based containment solutions, which separates cold and hot air from equipment to the data center.



### Beautiful Appearance

Tempered glass containment doors and ceiling panels.



### Security

Locking doors with card, passcode and optional fingerprint access control.



### Automatic Operation

Automatic containment doors and top panels can sync with building fire systems.



### Modular Design

Simple to configure containment roof, cabling and insulation components

## Product Highlights



Automatic Sliding Doors with Beautiful, Tempered Glass and Fully Locked Functions



Telescopic Roofs for Hot-Air Return

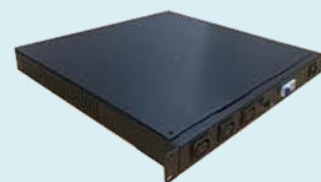

System Controller for Automatic Operation



Top Panels with Automatic Release

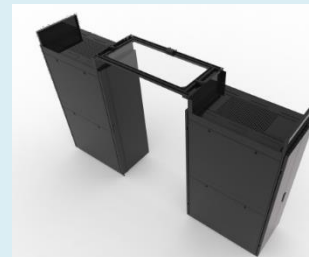

Modular, Sealed Rack & Panel Components



# ArcTiv Racks and Aisle Containment

## APPLICATION OVERVIEW

### Increase Data Center Cooling Efficiency

Data centers can use raised floors and containment solutions to isolate and recirculate hot & cold air.

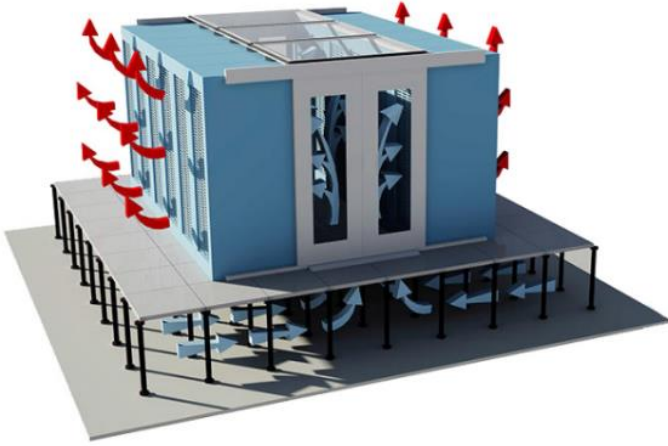

#### Cold-Aisle Containment

- Supports centralized, underfloor or in-row cooling
- Automated top panels sync to fire suppression
- Optional rack mounted telescopic chimneys

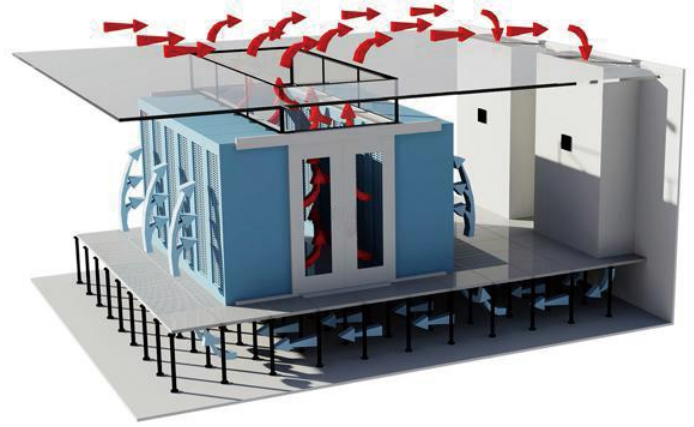

#### Hot-Aisle Containment

- Supports centralized, underfloor cooling systems
- Hot-air aisle recirculation
- Hot-aisle chimney

### Success Story

Server Room with ArcTiv Server Racks, Cold Aisle Containment and iPDU's.



#### Popular Markets

- Colocations
- Finance
- Government
- Enterprise

#### ArcTiv Value

- Quality Design
- Turnkey Solutions
- Customizable to Room
- Simple to Deploy
- Technical Training & Support



# ArcTiv Aisle Containment

## AUTOMATIC OPERATION



### Automatic Sliding Door (Aluminum)

- Left and Right Sliding Door, Automatic Switch
- Aluminum Profile with Tempered Glass
- Power Input: 100VAC – 240VAC, 50/60Hz
- Access Control: Card, Password, Fingerprint
- Autolock Door
- Wireless Button Switch for Exit
- Fire Alarm



### Semi-Automatic Swing Door (SPCC)

- 90° Swing Door with Manual Open, Auto Close
- SPCC with Tempered Glass
- Power Input: 12VDC
- Access Control: Card, Password, Fingerprint
- Electromagnetic Lock
- Switch Button for Exit
- Fire Alarm



### Rotary Roof Ceiling

- Compatible with 600 & 800mmW Racks
- Containment Aisle Width: 1200 or 1000mm
- Rotating Angle: 90°
- 5mm Tempered Glass, SPCC
- Electromagnetic Lock (12VDC)
- Supports Fire System Linkage
- Lighting Options
- Emergency Switch Options



### Fixed Roof Ceiling

- Compatible with 600 & 800mmW Racks
- Containment Aisle Width: 1200 or 1000mm
- Fixed, 5mm Tempered Glass or Sheet Metal
- Lighting Options
- Emergency Switch Options



# ArcTiv Aisle Containment

## ASSEMBLY AND ACCESSORIES

### Rack and Aisle Containment Assembly

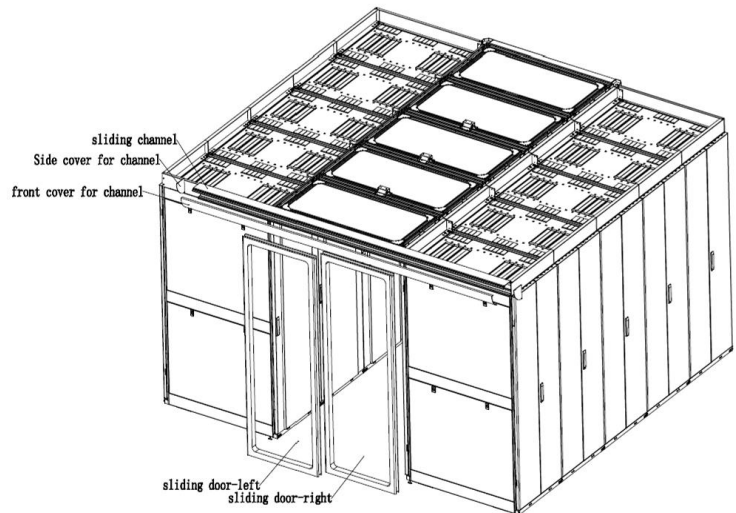
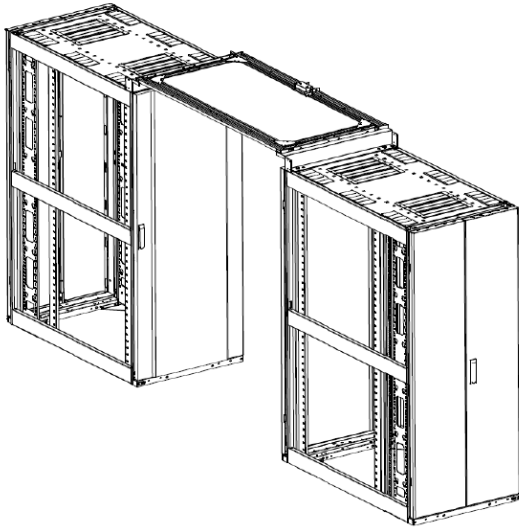

### Modular Components

- Server & Network Rack with Roof Panels
- Scalable for Future Expansion
- Conform to Tile Floor Dimensions

### Assembled Doors

- Automatic Sliding Tracks
- Fully Sealed Operation
- Access Control

### System Components & Accessories

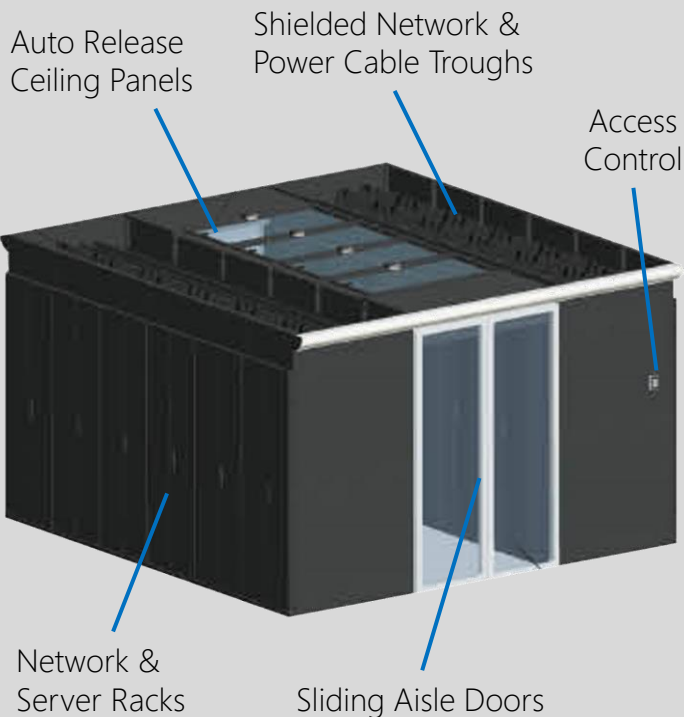

Power Control Box



Bottom Seal



Telescopic Chimneys



Top Cable Troughs





[www.arctiv-tech.com/](http://www.arctiv-tech.com/)



[sales@arctiv-tech.com](mailto:sales@arctiv-tech.com)



[facebook.com/arctivtechnologies](https://facebook.com/arctivtechnologies)



[linkedin.com/company/arctiv-technologies](https://linkedin.com/company/arctiv-technologies)



Power



Protect



Cool



Connect

ArcTiv Technologies is a global technology vendor whose mission is to **Power, Protect, Cool and Connect** your data center and edge-computing network infrastructure.

**USA Address:**

ArcTiv Technologies, LLC  
30 N Gould St Ste 22117,  
Sheridan, WY 82801  
USA  
e: [sales@arctiv-tech.com](mailto:sales@arctiv-tech.com)

**Taiwan Address:**

ArcTiv Technologies, Ltd.  
15f., No. 159, Sec 1, Keelung Rd.,  
Xinyi Dist. Taipei City, 110  
Taiwan (R.O.C.)  
e: [zill.tsai@arctiv-tech.com](mailto:zill.tsai@arctiv-tech.com)

**Bangladesh Address:**

ArcTiv Technologies, Ltd.  
Plot-155/1, 156, Road No. 1, Block-A,  
Section-12, Pallabi, Dhaka, PO: 1216  
Bangladesh  
e: [iftekhar.priyom@arctiv-tech.com](mailto:iftekhar.priyom@arctiv-tech.com)

© 2021 ArcTiv Technologies, LLC. All rights reserved. ArcTiv and the ArcTiv logo are trademarks or registered trademarks of ArcTiv Technologies, LLC. While every precaution has been taken to ensure accuracy and completeness herein, ArcTiv Technologies LLC assumes no responsibility, and disclaims all liability, for damages resulting from use of this information or for any errors or omissions. Specifications are subject to change without notice.